

# Electraray® Hazardous Location LED Flashing Warning Light with XLT™



## LED-BASED WARNING LIGHT FOR HEAVY-DUTY INDUSTRIAL APPLICATIONS

- XLT™ Technology
- Available in 24VAC/DC, 120VAC and 240VAC
- Five lens/lamp colors
- Flashing mode standard, configurable to Steady-burn
- 60,000-hour, vibration-resistant LED lamp
- 1/2 - inch pipe mount
- Type 4X, IP66 enclosure, Marine Listed
- UL and cUL Listed

### Model 225XL

The Model 225XL is a hazardous location flashing signal light that features the super bright LED array with XLT™, eXtreme Light Technology. The unit is available in 24VAC/DC, 120-240VAC self detecting voltage and five colors – amber, blue, green, red and clear. The 225XL comes standard in flashing mode and is field configurable to steady burn mode for maximum functionality.

The Model 225XL has been certified by UL as meeting Type 4X watertight and corrosion-resistant requirements, and is rated for Division 2 applications. This hazardous location warning light has a black polyurethane-coated base and the inner Fresnel lens is available in five colors – amber, blue, green, red and clear. The clear polycarbonate outer dome can be quickly removed for access while changing the LED or inspecting the unit.

Federal Signal's super bright LED array used in the 225XL with XLT inside produces intense light output and 60,000 hours of service. Increased shock and vibration resistance add to this unit's rugged industrial portfolio of features.

The 225XL is UL Listed for Class I, Division 2, Groups A, B, C and D; Class II Division 2, Groups F and G; and Class III.

The Federal Signal Model 225XL is ideal for wet, corrosive atmospheres like those found in food processing industries or anywhere a vibration-resistant visual signal is needed.

Model	Voltage	Operating Current	In-rush Current	Flash Rate/Minute	Mount
225XL	24VAC/DC	0.38 amps	1.75 amps, 5.0 mS	60	1/2" Pipe
225XL	120VAC	0.21 amps	2.00 amps, 0.25 mS	60	1/2" Pipe
225XL	240VAC	0.13 amps	2.00 amps, 0.25 mS	60	1/2" Pipe



# ELECTRARAY® HAZARDOUS LOCATION LED LIGHT (225XL)

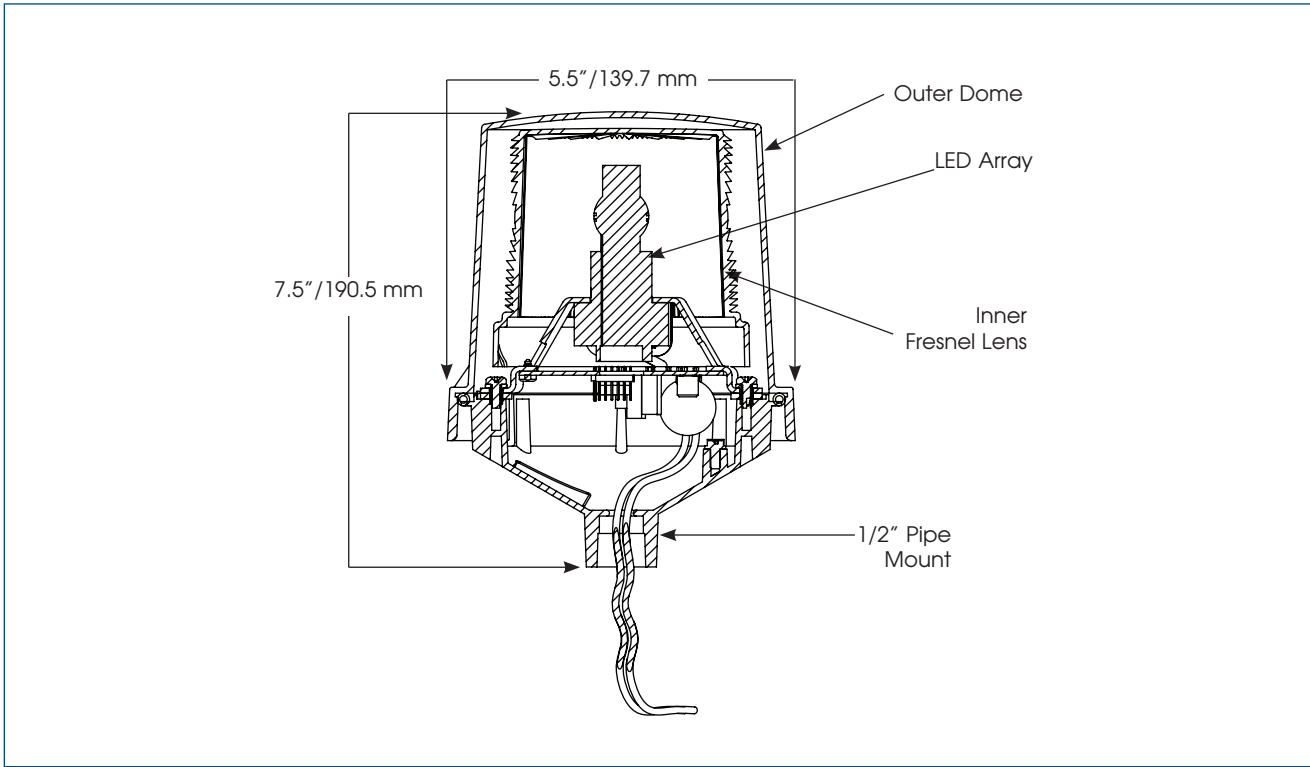

## SPECIFICATIONS

Lamp Life*:	60,000 hours	60,000 hours
Lamp Style:	LED-based Lamp	LED-based Lamp
Operating Temperature:	-58°F to 150°F	-50°C to 66°C
Net Weight:	3.2 lbs.	1.5 kg
Shipping Weight:	4.0 lbs.	1.8 kg
Height:	7.5"	190.5 mm
Diameter:	5.5"	139.7 mm

\* Optimal hours under ideal conditions.

## HOW TO ORDER

- Specify model, voltage and color
- Please refer to Model Number Index 225XL beginning on page 372

## REPLACEMENT PARTS

<u>Description</u>	<u>Part Number</u>	<u>Description</u>	<u>Part Number</u>
Exterior Dome, Clear	K8444D219C-04	PC Board Assembly, 24VAC/DC	K2005455A
Interior Lens, Amber	K8550292A-02	PC Board Assembly, 120/240VAC	K2005416A
Interior Lens, Blue	K8550292A-01	LED Lamp, Amber	K147169A-06
Interior Lens, Clear	K8550292A	LED Lamp, Blue	K147169A-07
Interior Lens, Green	K8550292A-04	LED Lamp, Clear	K147169A-10
Interior Lens, Red	K8550292A-03	LED Lamp, Green	K147169A-08
		LED Lamp, Red	K147169A-09