

Electronic Siren

Model SST-MV



ELECTRONIC SIREN WITH FOUR SELECTABLE TONES

- Multi-voltage design accepts 24VDC and 120/240VAC
- Produces one of four tones – wail, yelp, horn and temporal slow whoop
- Produces 109.5-111dBa @ 10'
- Omni-directional swivel mount
- Type 3R enclosure (with WB backbox)
- UL and cUL Listed

Federal Signal's SST-MV is an electronic siren capable of producing one of four high decibel tone outputs from the same unit.

The Model SST-MV features internal amplification and the tone circuitry to produce four different tones. The user selects from the wail, yelp, horn or temporal slow whoop tone by reconfiguring internal jumpers.

The SST-MV operates on 24VDC, 120VAC or 240VAC. The TYPE 3R housing is molded from impact-resistant ASA (acrylic-styrene-acrylonitrile) plastic, making it resistant to ultra-violet light and ideal for indoor or outdoor use.

The omni-directional swivel mount system allows the output to be pointed anywhere within a 360° half-sphere.

This electronic siren is UL and cUL Listed.

The Model SST-MV can be used as a stand-alone, high output, audible warning device in any application where voice paging is not required.

Typical applications include emergency warning, start and dismissal, fire alarm, general alarm and evacuation.

Federal Signal's Model SST-MV Electronic Siren is an economical multi-tone siren that is designed to hold up to the rigors of corrosive environments.

Model	Voltage	Operating Current
SST-MV	24VDC	600mA
SST-MV	120VAC	210mA
SST-MV	240VAC	120mA

Tone	Decibels @	
	10'	1m
Wail	109.5	119.5
Yelp	111.0	121.0
Horn	107.0	117.0
Temporal Slow Whoop	111.0	121.0



ELECTRONIC SIREN (SST-MV)

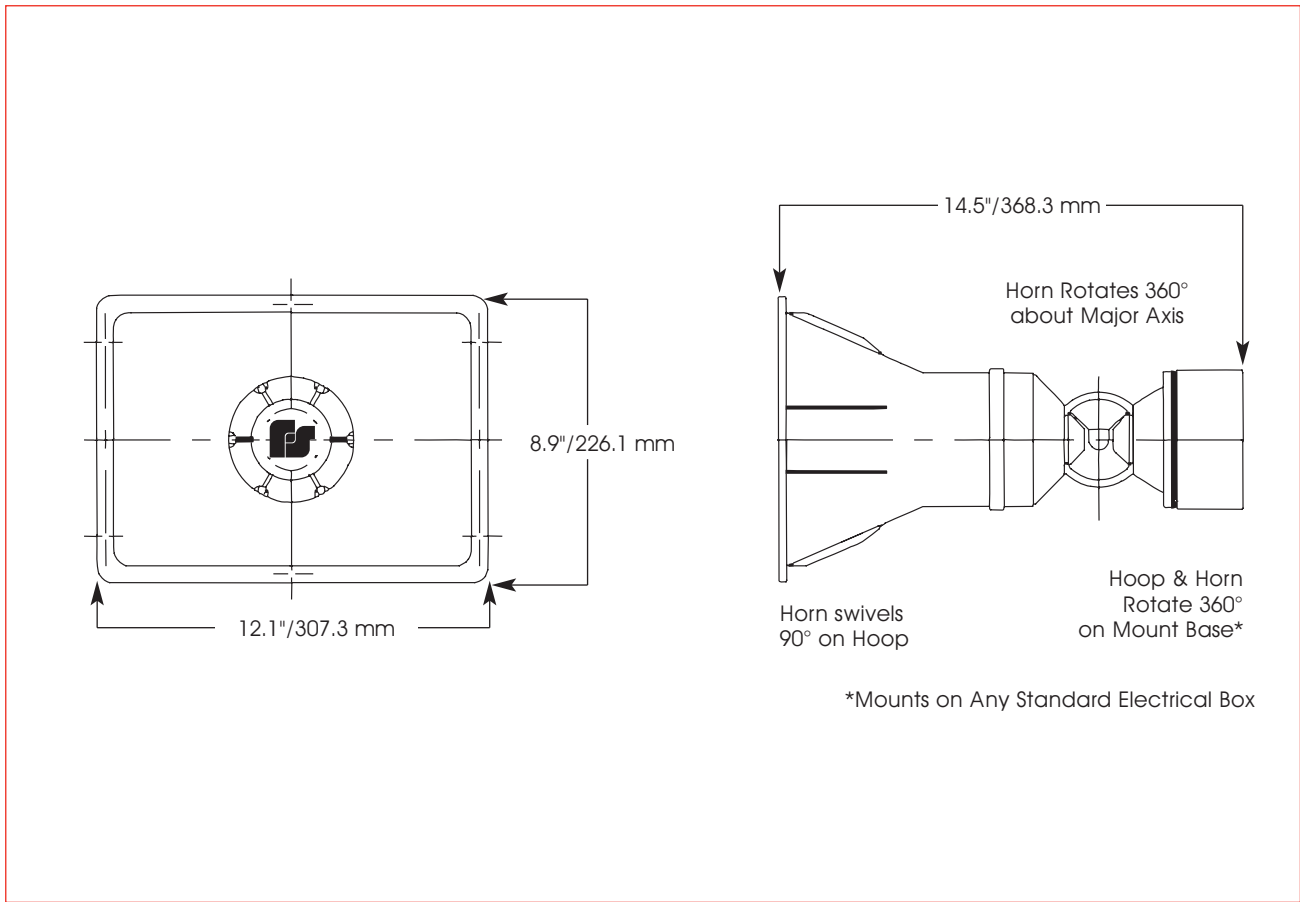

SPECIFICATIONS

Operating Temperature:	-31°F to 161°F	-35°C to 72°C
Shipping Weight:	5.2 lbs.	2.4 kg
Net Weight:	4.4 lbs.	2.0 kg
Height:	14.5"	368.3 mm
Width:	12.1"	307.3 mm
Depth:	8.9"	226.1 mm

HOW TO ORDER

- Specify model
- Specify options:
Weatherproof Backbox (WB)
4" Electrical Box (NB)
- Please refer to Model Number Index SST-MV beginning on page 378

REPLACEMENT PARTS

<i>Description</i>	<i>Part Number</i>
PC Board Assembly	K2001177D-01
Connector, 4-Position	K140340B
Adapter (Beige)	K8476121A
Adapter (Grey)	K8476121A-04
Gasket	K8476122A